

Gas Dedection Systems



Addressable Toxic and Flammable Gas Detection Systems

Addressable gas detection systems are designed to detect toxic and flammable gases in parking lots and tunnels.



CO EFFECT

CO Level	Condition & Health Effects
0 ppm	Normal, fresh air
9 ppm	Maximum value to be exposed for a short time
10-24 ppm	Long-term expose influences health
25 ppm	Maximum 8 hours TWA level
50 ppm	Maximum allowed in work area
100 ppm	Slightly headache after 1-2 hours
200 ppm	Dizziness, nausea, tiredness, headache after 2-3 hours of expose
400 ppm	Pain and nausea after 1-2 hours exposure / life threat within 3 hours
800 ppm	After 45 minutes headache, nausea and dizziness Collapse after 1 hour and loss of consciousness / death within 2-3 hours
1.600 ppm	Headache after 20 minutes, nausea and dizziness / death within 1-2 hours
3.200 ppm	After 5-10 minutes headache, nausea and dizziness Collapse after 30 minutes and loss of consciousness / death within 1 hour
6.400 ppm	Death in 30 minutes
12.800 ppm	Immediate physiological effects within 1-3 minutes, loss of consciousness / Death



Level	Condition & Health Effects
5 ppm	Chronic Bronchitis, Emphysema, Eye and nose irritation, Upper respiration
1 ppm	Headache, Cough, Edema, Eye and nose irritation, Upper respiration
0,2 ppm	< Low irritation



SENSOR WORKING PRINCIPLE

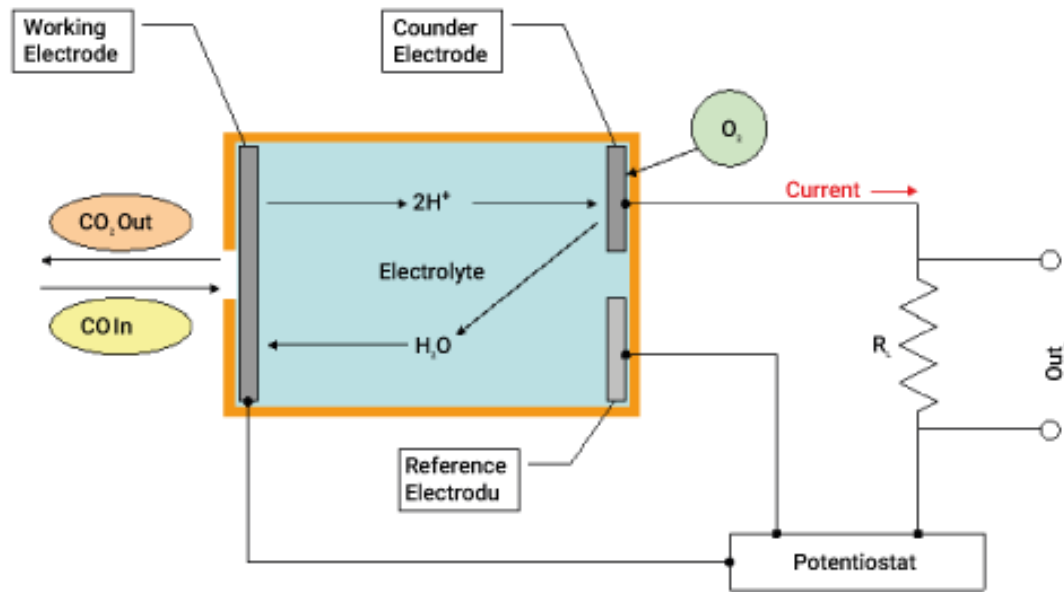

CO Reactions

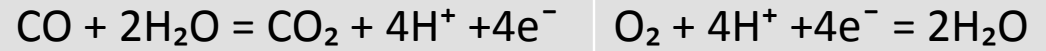

NO₂ Reactions

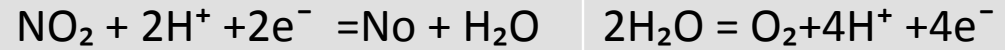

NO Reactions

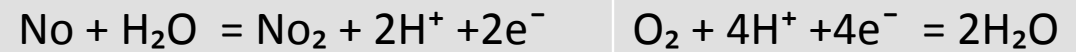

WHY DO WE REQUIRE THE SYSTEM ?

1-Security

2-Economic

2.1-Electricity consumption & when the fan is not working continuously, consumption is less

2.2-Engine life becomes longer

2.3-Heat loss

2.3.1-Heat loss is greater when continuous air is needed

3- Quiet environment

4- Regulation

SIMPLE SENSOR PLACEMENT

Sensor Mounting Height: 1.5m
Protection Range: 725m²

 Sensor

Sensor location diagram
for single level car park structure

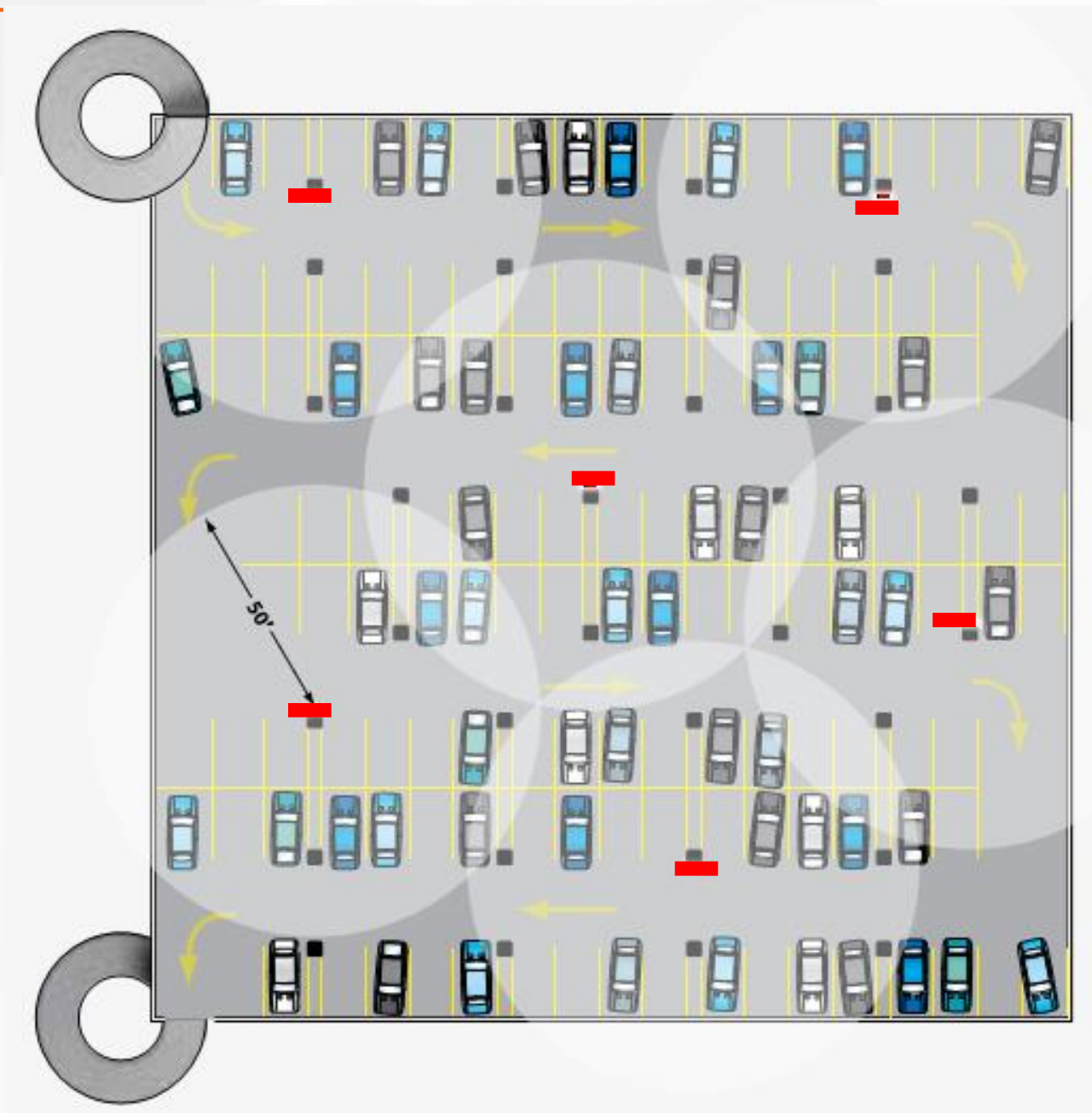

Underground Garage / Parking Lot Structure
 Approximately 350 for automobiles 9290m² for parking lot
 Approx. 75 HP (Horsepower), Combination of all fans
 12 hours / day and 7 days / week garage operation

HP (Horsepower) - Watt (Electrical Power) Conversion
 (In this example, fan motor efficiency and load factor cancel to each other)
 75 HP x 746 Watt / HP = 55,950 Watt, and 1,000 = 55.95 kWatts.

Annual Fan Power Consumption (kWh)	Control without Gas Detection 12 hour / day x 365 day x 55,95kWatts = 245.061 kWh	
	Gas Detection Control 2 hour / day x 365 day x 55,95kWatts = 40.844 kWh	
Annual Savings	KWh Savings per year: No Demand Control 245.061 kWh Demand Control - 40.844 kWh Saving = 204.217 kWh	Annual Electricity Saving: 204.217 kWh x 11 cent 1 kWh Saving = 22.500 USD
Return of Investment	Up to 8 - 18 months	

Alarm Lights	Definition
Blue	Fault
Amber	Low carbon monoxide
Red	High carbon monoxide

Warning signs

- Warning signs must clearly define the situation of the visual and audible alarm devices system condition.
- Warning signs should be placed close to the alarm devices.
- The signs must be at least 40 cm² (16 inches).
- There should be black text on a white background.

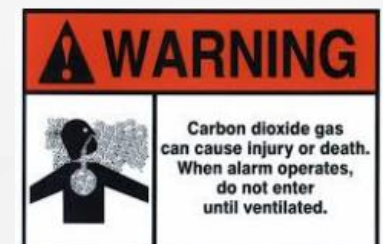

- Electrochemical
- Sensitive 1 ppm
- 12-18 months calibration <12 months EN 50545
- Maintenance cost is low, accuracy is high
- Compulsory for TSE EN 50545



0-300 ppm



CO, NO₂, NO SENSOR PROPERTIES

- Built-in short-circuit isolator
- Power Line Communication (PLC)
- 2 wire connection
- Test
- Microprocessor control
- Calibration
- Fault
 - Communication
 - I2C
 - Calibration fault



CO, NO, NO₂, CH₄



0-300 ppm



0-30 ppm



0-100 ppm



0-100 ppm



Short-circuit Isolator

- < 12 month TSE EN 50545
- Calibration in the field on side
- Gas + Calibration Chamber
- Factory, Calibration Test Room



Easy Calibration
at Field



Calibration Chamber

Measurement Range

Gas	Values
CO	0 – 300 ppm
NO ₂	0 – 30 ppm
NO	0 – 100 ppm

Levels

Gas	Alarm 1	Alarm 2	Alarm 3
CO	30	60	150
NO ₂	3	6	15
NO	10	20	50
	15 min TWA	15 min TWA	1 min continuous
	± %3		

PANEL PROPERTIES



7" LCD
Touch Screen Display



1000 Unit
Connection



3 Level Alarm
Indicator



12 LED
Indicator



4 Loop
Connection



Built-in 8 Channel
Relay Connection

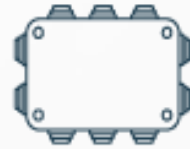

Built-in 8 Channel
4-20mA Connection



Built-in Buzzer
and Speaker



Accumulator
Connection



RS485 and Ethernet
Connection



Built-in real-time
clock



Sounder Output



SYSTEM SETUP / MAIN DIAGRAM

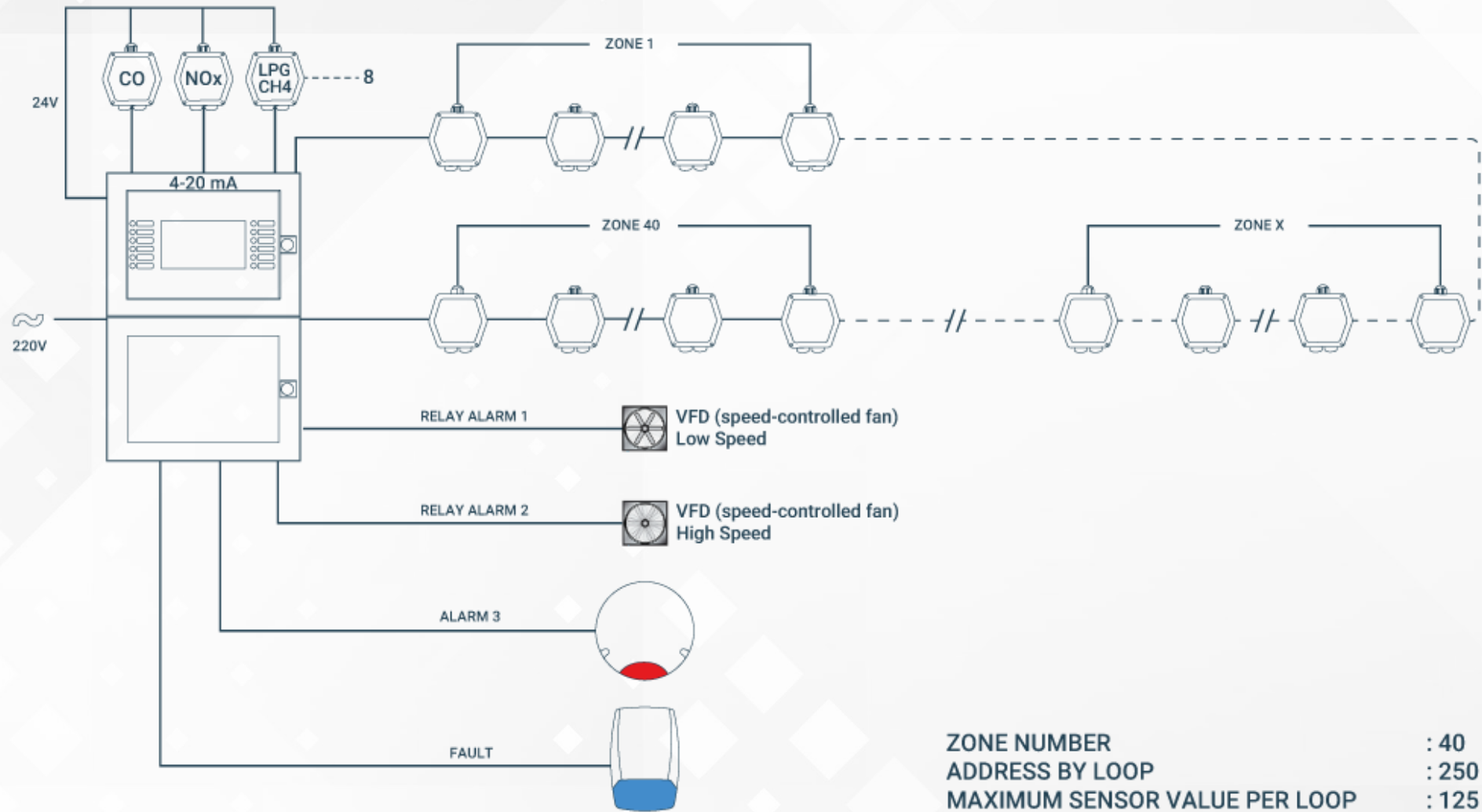

ZONE NUMBER : 40
ADDRESS BY LOOP : 250
MAXIMUM SENSOR VALUE PER LOOP : 125

SYSTEM SETUP / REGIONAL

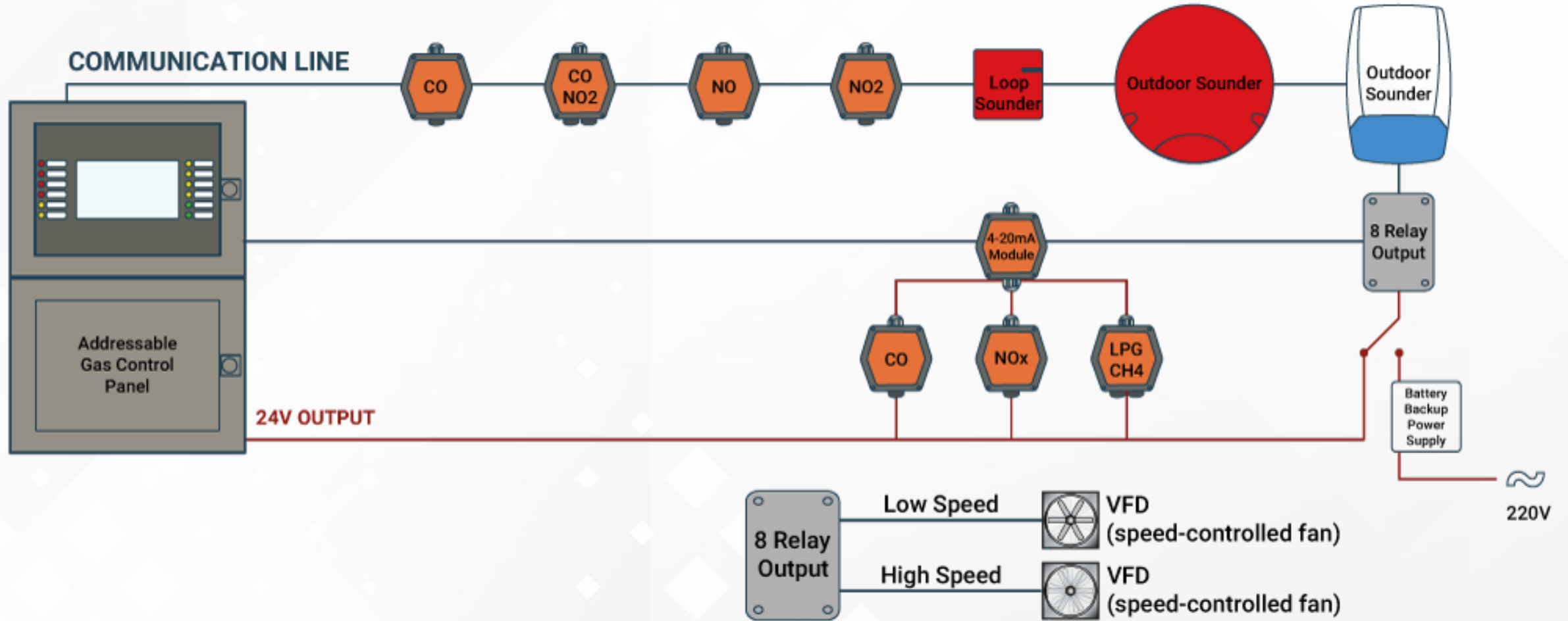

SCOPE OF APPLICATION



Car Park



Tunnel



Nuclear Industry

SCOPE OF APPLICATION



Laboratory



Mining



Agriculture

SCOPE OF APPLICATION



Steel Mill



Marine



Oil and Gas
Industry

THANK YOU

